

Multipurpose Valve for Filling and Liquid Transfer of NH₃ Containers A8018DP

Application

Designed primarily for use as a combination filler and liquid withdrawal valve on three-opening applicator tanks or on nurse tanks.

This valve incorporates an integral excess flow valve. When product is required, the valve must be completely open and backseated to allow the excess flow valve to function properly as explained in the excess flow valve section of this catalog.

Features

- Functions as both a filler valve and liquid transfer valve, in one unit.
- Positive acting excess flow valve opens for maximum flow at minimum pressure drop when filling — regardless of the type of coupling in which the valve is installed.
- Excess flow seat is fully contained in the tank coupling for maximum protection in the event of external damage to the valve.
- Specially machined break-away groove beneath ACME thread of filler valve will shear-off with excessive pull on the hose and leave the valve body intact.
- Triple guide filler valve check provides for dependable shut-off performance when filling ceases.
- Resilient seat disc assembly is fully contained on three sides for bubble-tight shut-off and long service life.
- "V"-ring spring loaded stem seal design requires no repacking or field adjustment.
- Plugged 1/4" NPT boss accommodates vent valve or hydrostatic relief valve.

Materials

Body	Ductile Iron
Bonnet	Steel
Stem	Stainless Steel
Seat Discs	Synthetic Resilient Rubber
"V"-Rings	Teflon
Excess Flow Valve	Stainless Steel - Steel Body
Springs	Stainless Steel



A8018DP

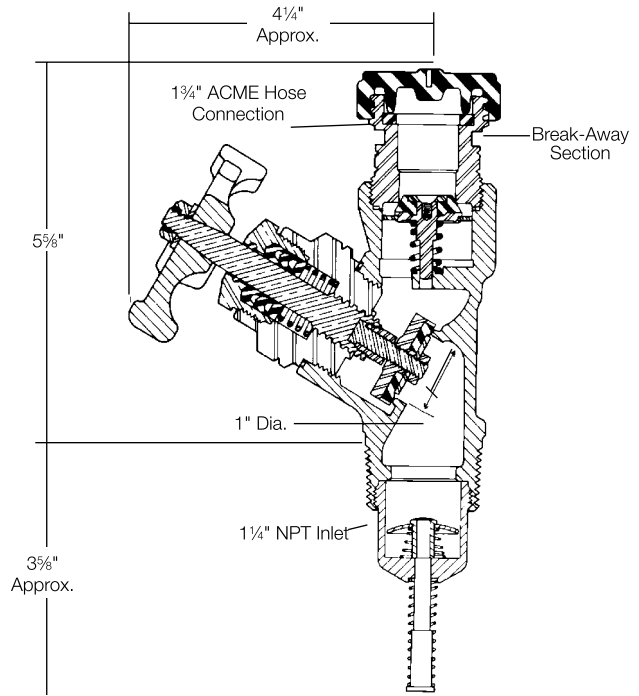

Ordering Information

Part Number	Inlet Connection (M. NPT)	Outlet Connection (F. NPT)	Filling Connection (M. ACME)	Filling Capacity At 20 PSIG Pressure Drop GPM/NH ₃	Approximate Excess Flow Liquid Closing Flow GPM/NH ₃	Accessories	
						Hydrostatic Relief Valve	Vent Valve
A8018DP	1 1/4"	1"	1 1/4"	74	50	SS8001J	TSS3169

* Determined at 9 to 12 PSIG differential.